

MODEL NUMBER					
BOX 1 MODEL CODE	BOX 2 SEALS	BOX 3 INLET PORTING	BOX 4 OUTLET PORTING	BOX 5 STAGE 1 INDICATOR	BOX 6 TEST POINTS
BCC300	V=VITON	P24=1 1/2" NPT P32=2" NPT P32=2" SAE 4-BOLT FLANGE CODE 61	P24=1 1/2" NPT P32=2" NPT P32=2" SAE 4-BOLT FLANGE CODE 61	OMIT=NONE D5=VISUAL POP-UP D5C=VISUAL POP-UP IN CAP DPG=DIFFERENTIAL PRESSURE GAUGE MS10=ELECTRICAL W/DIN CONNECTOR (MALE END ONLY)	OMIT=NONE UU=TEST POINTS IN EACH STAGE

REPLACEMENT CARTRIDGE		
STAGE	PART NUMBER	QTY.
1	BCC39QPRE	1
2	BCC39QPOL	1
3	BCC39QPOL	1

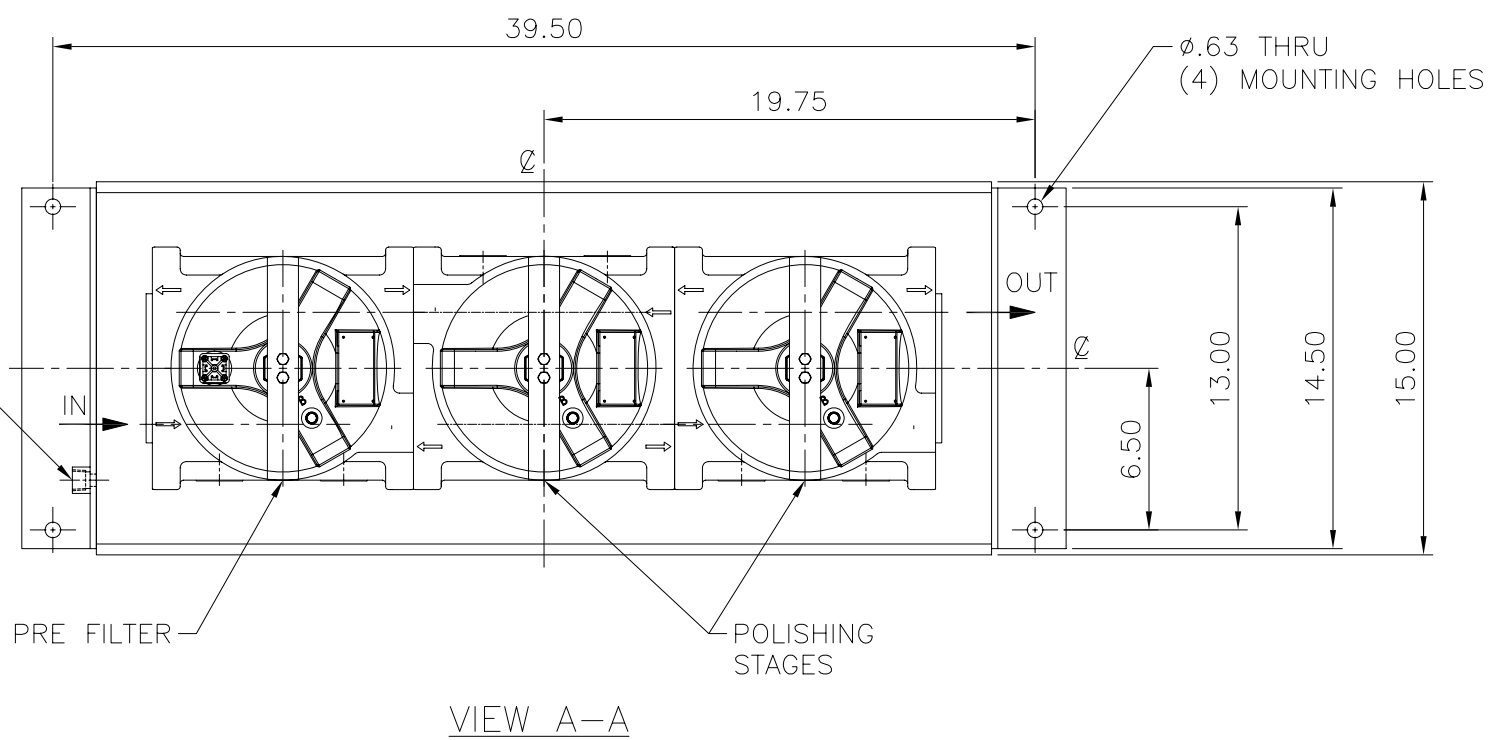

PRELIMINARY

ALL DIMENSIONS SHOWN MAY CHANGE PENDING FINAL DESIGN. IF DIMENSIONS SHOWN MUST BE HELD WITHIN A CERTAIN TOLERANCE, PLEASE INFORM SCHROEDER INDUSTRIES LLC FOR APPROVAL.

- NOTES:
- COATING:
 - INTERNAL: NONE
 - EXTERNAL: STAGE 1 - IMRON GREEN S.I. SPEC. #144, 145, 146
 - STAGE 2 - IMRON BLACK S.I. SPEC. TBD
 - HOUSING WILL ACCOMMODATE CARTRIDGE PER REPLACEMENT CHART.
 - ESTIMATED EMPTY WEIGHT: TBD

MATERIAL:	DEC. TOLERANCES	ALL DIMENSIONS IN INCHES [MM]	REV. CARD:
	2 PL. ±	APP. A.MILLER 8/28/09	REV. DATE:
	3 PL. ±	CHK. A.MILLER 8/28/09	B/M
	ANG. ±	DWN. A.BOST 8-24-09	P/N

SALES DRAWING OF
BCC300
SKID

THESE DRAWINGS, SPECIFICATIONS, AND THE IDEAS CONTAINED HEREIN ARE THE EXCLUSIVE PROPERTY OF SCHROEDER INDUSTRIES LLC AND ARE CONFIDENTIAL. THESE DOCUMENTS SHALL NOT BE COPIED OR REPRODUCED IN PART OR IN FULL AS A BASIS OF DESIGN, MANUFACTURE, OR SALE; AND SHALL NOT BE USED IN ANY WAY DETRIMENTAL TO THE INTEREST OF THIS COMPANY. THEY ARE SUBJECT TO RETURN UPON REQUEST.



REV. DRAWING NO.
D-11104
SCALE: 1/4"=1" SHT. 1 OF 1